

**MEDIUM VOLTAGE  
POWER STATION  
CUSTOMIZED UP  
TO 7.65 MVA, WITH  
ALL THE UL-LISTED  
COMPONENTS  
SUPPLIED ON TOP  
OF THE SAME  
SKID PLATFORM**

## From 2500 up to 7650 kVA

This medium-voltage solution integrates all the necessary elements to develop a large-scale solar PV plant.

### **Maximize your investment with a minimal effort**

Ingeteam's FSK power station is a compact, customizable and flexible solution that can be configured to suit each customer's requirements. It is supplied together with up to two photovoltaic inverters. All the equipment is suitable for outdoor installation, so there is no need of any kind of housing.

### **Higher adaptability and power density**

This power station is now more versatile, as it presents the MV transformer integrated into a steel platform together with the LV and MV components, including the PV inverters. Moreover, it features one of the market's greatest power densities.

### **Plug & Play technology**

This MV solution integrates power conversion equipment (up to 7.65 MVA), liquid-filled hermetically sealed transformer 36 kV class and

provision for low voltage equipment. The MV Skid is delivered pre-assembled for a fast on-site connection with up to two PV inverters from Ingeteam's INGECON® SUN 3Power C Series inverter family.

### **Complete accessibility**

Thanks to the lack of housing, the inverters, the switchgear and the transformer can have immediate access. Furthermore, the design of the 3Power C Series central inverters has been conceived to facilitate maintenance and repair works.

### **Maximum protection**

Ingeteam's 3Power C Series central inverters feature an NEMA 3 protection class for their power stacks thanks to a combined water and air cooling system that optimises the operating temperature of the power electronics.

Apart from that, they feature the main electrical protections and they deploy grid support functionalities, such as low voltage ride-through capability, reactive power deliverance and active power injection control.

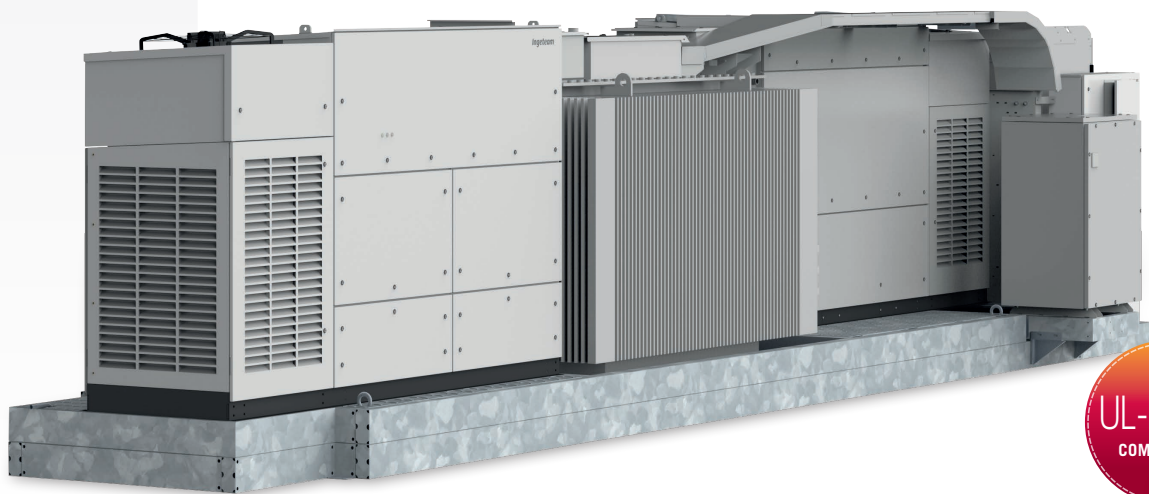

**CONSTRUCTION**

- Steel base frame.
- Suitable for slab or piers mounting.
- Compact design, minimising freight costs.
- Minimum installation at project site.

**OPTIONAL ACCESSORIES**

- Auxiliary services transformer (up to 60 kVA, Dyn11).
- MV Surge arresters.
- Self-power auxiliary services panel.
- High-speed Ethernet / fibre optic communication switch.
- INGECON® SUN StringBox with 16 / 24 / 32 input channels. Intelligent or passive string combiner box.
- Energy meter for energy production.
- Reactive power regulation when there is no PV power available.
- Ground connection of the PV array.

**STANDARD EQUIPMENT**

- Up to two inverters with an output power of 7.65 MVA.
- Liquid-filled hermetically-sealed transformer.
- 2L1A MV switchgear.
- Oil-retention tank.
- Metal frame for installation of LV equipment.

**COMPONENTS**

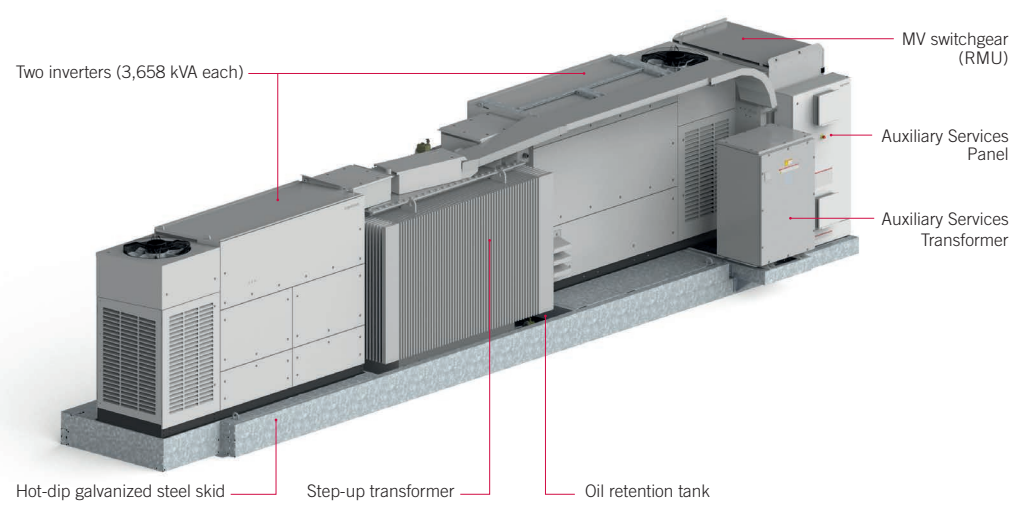

**PLANT CONFIGURATION**

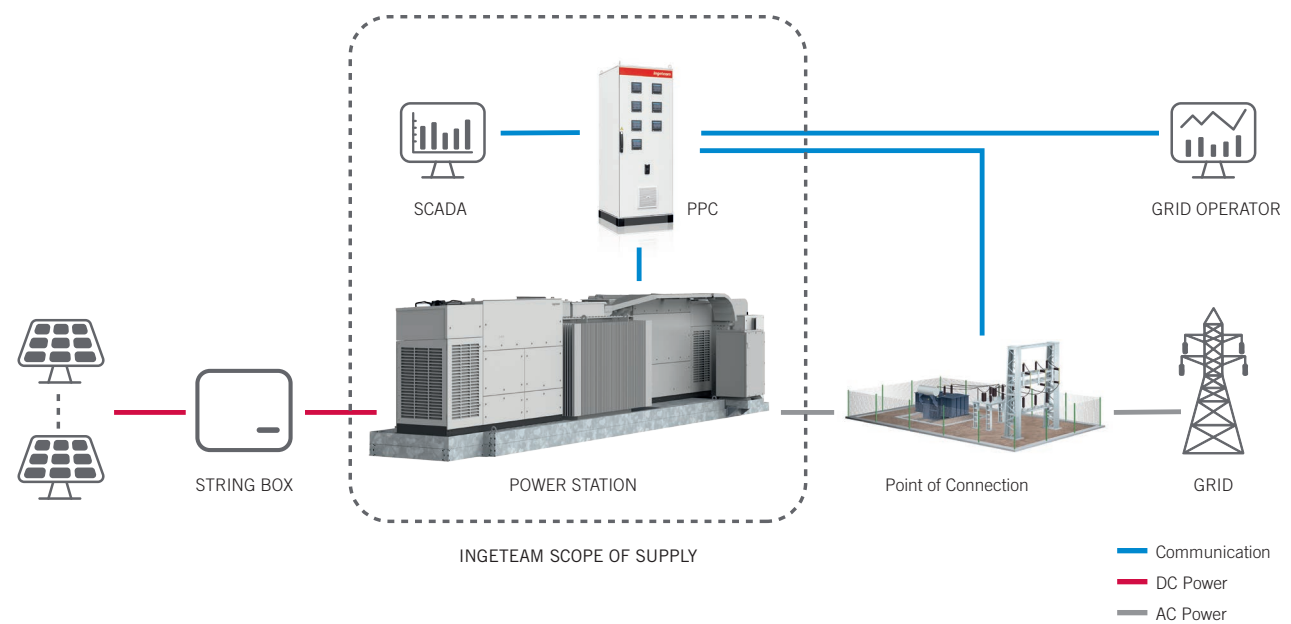

|   | 3825 FSK U C Series                                 | 7650 FSK U C Series       |
|---|---|---------------------------|
| <b>General information</b>                |   |                           |
| Number of inverters                       | 1   | 2                         |
| Max. power. @35 °C / 95 °F <sup>(1)</sup> | 3,658 kVA   | 7,316 kVA                 |
| Operating temperature range               | from -5 °C to +50 °C                                |                           |
| Relative humidity (non condensing)        | 0 - 100%  |                           |
| Maximum altitude                          | 4,500 masl (power derating starting at 1,000 masl)  |                           |
| <b>Step-up Transformer</b>                |   |                           |
| Medium voltage                            | 36 kV class, 50 / 60 Hz                             |                           |
| Cooling system                            | ONAN (KNAN optionally)                              |                           |
| Minimum PEI (Peak Efficiency Index)       | 99.50%  |                           |
| Installation                              | Readiness for outdoor installation                  |                           |
| <b>MV Switchgear (RMU)</b>                |   |                           |
| Medium voltage                            | 24 kV / 36 kV                                       |                           |
| Rated current                             | 630 A   |                           |
| Cooling system                            | Natural air ventilation                             |                           |
| Protection degree                         | IP54  |                           |
| <b>Equipment</b>                          |   |                           |
| Auxiliary services panel                  | IP54 self-powered LV panel                          |                           |
| Step-up transformer                       | Oil-immersed hermetically sealed transformer        |                           |
| MV Switchgear                             | 2L1A RMU as standard (0L1A1L, 1L1A & 0L1A optional) |                           |
| <b>Mechanical information</b>             |   |                           |
| Structure type                            | Hot dip galvanized steel skid                       |                           |
| Dimensions Full Skid (W x D x H)          | 9,500 x 2,600 x 2,620 mm                            | 11,390 x 2,600 x 2,620 mm |
| Full Skid                                 | 16 T  | 25 T                      |
| Standards                                 | IEC 62271-202, IEC 62271-200, IEC 60076             |                           |

**Notes:** <sup>(1)</sup> Maximum power calculated with the inverter model INGECON® SUN 3825TL C660. For other inverter models, please contact Ingeteam's Solar sales department.

**Configuration with two C Series solar inverters**

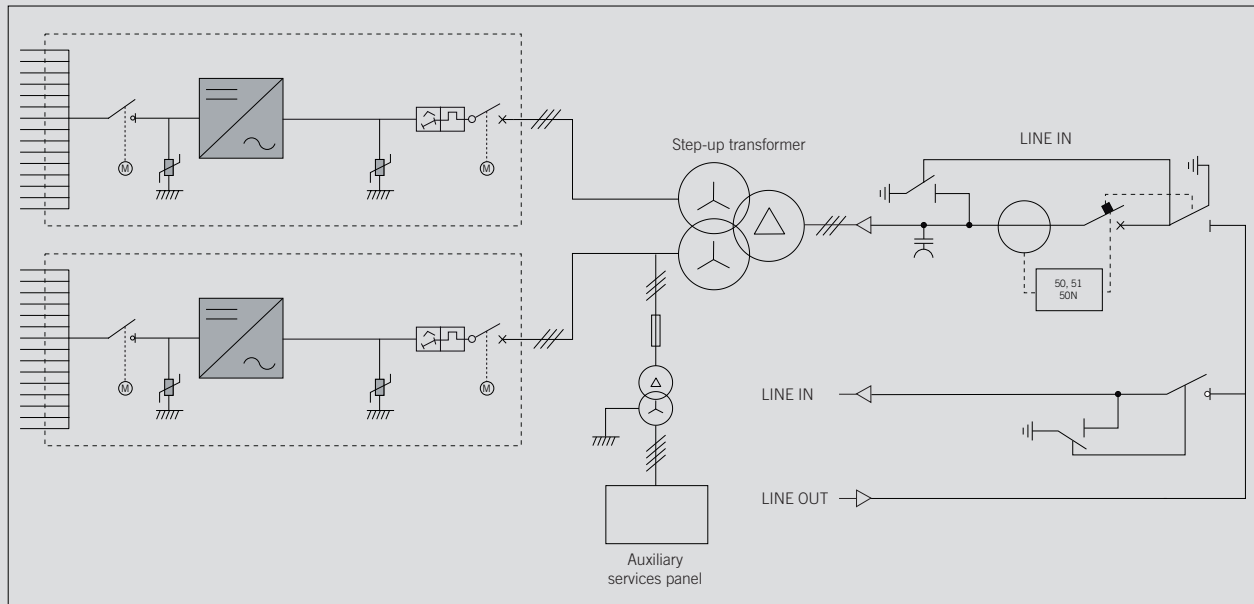

# Ingeteam

**Ingeteam Power Technology, S.A.**  
Avda. Ciudad de la Innovación, 13  
31621 Sarriguren (Navarra) - Spain  
Tel.: +34 948 288 000  
Fax: +34 948 288 001  
e-mail: solar.energy@ingeteam.com

**Ingeteam S.r.l.**  
Via Emilia Ponente, 232  
48014 Castel Bolognese (RA) - Italy  
Tel.: +39 0546 651 490  
Fax: +39 054 665 5391  
e-mail: italia.energy@ingeteam.com

**Ingeteam SAS**  
La Naurouze B - 140 rue Carmin  
31670 Labège - France  
Tel.: +33 (0)5 61 25 00 00  
Fax: +33 (0)5 61 25 00 11  
e-mail: france@ingeteam.com

**Ingeteam INC.**  
3550 W. Canal St.  
Milwaukee, WI 53208 - USA  
Tel.: +1 (414) 934 4100 / +1 (855) 821 7190  
Fax: +1 (414) 342 0736  
e-mail: solar.us@ingeteam.com

**Ingeteam, a.s.**  
Technologická 371/1  
70800 Ostrava - Pustkovec  
Czech Republic  
Tel.: +420 59 747 6800  
Fax: +420 59 732 6899  
e-mail: czech@ingeteam.com

**Ingeteam Shanghai, Co. Ltd.**  
Shanghai Trade Square, 1105  
188 Si Ping Road  
200086 Shanghai - P.R. China  
Tel.: +86 21 65 07 76 36  
Fax: +86 21 65 07 76 38  
e-mail: shanghai@ingeteam.com

**Ingeteam, S.A. de C.V.**  
Leibnitz Ext 13 Int 1102, Colonia Anzures  
11590 - Miguel Hidalgo  
Ciudad de México - Mexico  
Tel.: +52 81 8311 4858  
Fax: +52 81 8311 4859  
e-mail: northamerica@ingeteam.com

**Ingeteam Ltda.**  
Rua Estácio de Sá, 560  
Jd. Santa Genebra  
13080-010 Campinas/SP - Brazil  
Tel.: +55 19 3037 3773  
e-mail: brazil@ingeteam.com

**Ingeteam Pty Ltd.**  
Unit 2 Alphen Square South  
16th Road, Randjiespark  
Midrand 1682 - South Africa  
Tel.: +2711 314 3190  
Fax: +2711 314 2420  
e-mail: southafrica@ingeteam.com

**Ingeteam SpA**  
Los militares 5890, Torre A, oficina 401  
7560742 - Las Condes  
Santiago de Chile - Chile  
Tel.: +56 2 29574531  
e-mail: chile@ingeteam.com

**Ingeteam Power Technology India Pvt. Ltd.**  
2nd Floor, 431  
Udyog Vihar, Phase III  
122016 Gurgaon (Haryana) - India  
Tel.: +91 124 420 6491-5  
Fax: +91 124 420 6493  
e-mail: india@ingeteam.com

**Ingeteam Sp. z o.o.**  
Ul. Koszykowa 60/62 m 39  
00-673 Warszawa - Poland  
Tel.: +48 22 821 9930  
Fax: +48 22 821 9931  
e-mail: polska@ingeteam.com

**Ingeteam Australia Pty Ltd.**  
iAccelerate Centre, Building 239  
Innovation Campus, Squires Way  
North Wollongong, NSW 2500 - Australia  
Tel.: +61 429 111 190  
e-mail: australia@ingeteam.com

**Ingeteam Panama S.A.**  
Av. Manuel Espinosa Batista,  
Ed. Torre Internacional  
Business Center, Apto./Local 407  
Urb. C45 Bella Vista  
Bella Vista - Panama  
Tel.: +50 761 329 467

**Ingeteam Service S.R.L.**  
Bucuresti, Sector 2,  
Bulevardul Dimitrie Pompeiu Nr 5-7  
Cladirea Hermes Business  
Campus 1, Birou 236, Etaj 2  
Romania  
Tel.: +40 728 993 202

**Ingeteam Philippines Inc.**  
Office 2, Unit 330, Milelong Bldg.  
Amorsolo St. corner Rufino St.  
1230 Makati  
Gran Manila - Philippines  
Tel.: +63 0917 677 6039

**Ingeteam Power Technology, S.A.**  
Level 1, Al Bateen Tower C6 Bainunah  
ADIB Building, Street 34  
PO BOX 30010 - Abu Dhabi  
United Arab Emirates  
Tel.: +971 50 125 8244

**Ingeteam Vietnam Ltd.**  
Spaces - 28A Tran Hung Dao Street  
Phan Chu Trinh Ward  
Hoan Kiem District  
Ha Noi City - Vietnam  
Tel.: +84 24 71014057  
e-mail: vietnam@ingeteam.com

**Ingeteam Uruguay, S.A.**  
Avenida 18 de Julio, 1474, Piso 12  
11200, Montevideo, Uruguay  
Tel.: +598 934 92064