

Scope of Supply

Ingeteam Industry is responsible for the complete "Turnkey" electrical project:

- Project management
- Basic and detail engineering
- Supply of electrical equipment, drives and automation:

Low voltage distribution center
Auxiliary control voltage distribution
Emergency power UPS
Main DC drives – MOTOCON DC*
AC motor control center
Field sensors
Control desks and local panels
Integrated control equipment (SISTEAM M)*
Control and supervision equipment (OPERATOR MT)*
Intercommunication and PA system
Fire detection and passive protections

- Electrical erection
- Supervision of electrical erection
- Commissioning

(*) MOTOCON DC, MOTOCON AC, SISTEAM M and OPERATOR MT is equipment designed and manufactured by Ingeteam Technology.



Mill's Main Pulpit



Mill Overview



Cold Rolling Mill Coiler



DC Motor Control Center

After Sales Services

- Hotline
- Spare parts in 24 hours
- Direct line with our technical staff
- Remote communication from our offices to the factory automation network

Ingeteam Industry

Ingeteam

Cold Rolling Mill

VALENCIANA DEL ALUMINIO BAUX S.L.



Ingeteam

INGETEAM, A.S.
Technologická 371/1
70800 OSTRAVA-PUSTKOVEC
REPUBLICA CHECA
Tel.: 420 59 732 68 00
E-mail: czech@ingeteam.com

INGETEAM GmbH
Stielerstrasse, 3
80336 MUNICH - ALEMANIA
Tel.: 49 89 99653855
E-mail: deutschland@ingeteam.com

INGETEAM INDUSTRY, S.A.
Parque Tecnológico. 106
48170 ZAMUDIO (BIZKAIA) - ESPAÑA
Tel.: (+34) 94 4039720 Fax.: 94 4039688
E-mail: industry@ingeteam.com
www.ingeteam.com

INGETEAM, LTDA
Rua Luiz Carlos Brunello, 286
Chácara Sao Bento
13278-074-Valinhos SP-BRAZIL
Tel.: 55 19 30 37 37 73
E-mail: brazil@ingeteam.com

ENSILECTRIC, S.A.
Parque Tecnológico Asturias
Edif. Centrolena nº 46-2ª planta
33428 Llanera (ASTURIAS) - ESPAÑA
Tel.: (+34) 98 5268012
E-mail: ensilectric@ensilectric.com

Ingeteam
industry

Mill Description

VAI Cosim the Spanish subsidiary of the VATECH group (Voest Alpine) has commissioned **Ingelectric Team (currently Ingeteam Industry)** during the second half of 1999, to design, supply and install the state-of-the-art Electrical and Automation Equipment for an aluminium Cold Rolling Mill. The end user is **Valenciana del Aluminio, BAUX** in Segorbe (Castellón), Spain.

The aim of the mill is to process the coils obtained in the Hot Rolling Mill, also automated by Ingeteam Industry. It consists of a QUARTO mill stand (two working rolls and two back-up rolls), coiler and uncoiler.

The main drives feature DC motors reconditioned from another installation, driven by new digitally-controlled thyristor rectifiers (MOTOCON DC).

The mill automation was carried out by PLC control systems: 1 single PLC acts as master control system in addition to control the auxiliary drives, spraying systems, lubrication and hydraulics.

The master control system executes the thickness control functions, manual bending and tilting, torque and speed setpoint generation for mill stands and coilers.

Valenciana del Aluminio BAUX, s.l. supplies the thickness gauges.

The automation also includes HMIs (Human Machine Interfaces) in the control pulpit, as shown in the drawing, which make easy to the user the mill adjustment, control and tracking. This system is based on PC and incorporates the operation and monitoring software.

Technical Features

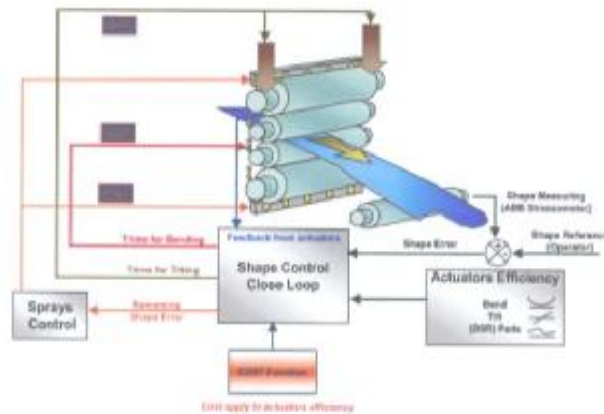

Minimum Thickness	
Entry	1.3 mm
1st Mill Pass	0.7 mm
2nd Mill Pass	0.4 mm
3rd Mill Pass	0.25 mm
Production Data	
Coils Diameter	from 508 to 1,800 mm
Coiler Speed	up to 580 m/min
Annual Production	45,000 Ton
Other data	
Mill's Force	1,000 Ton
Cylinders' Spraying	1,600 l/min

Control Diagram

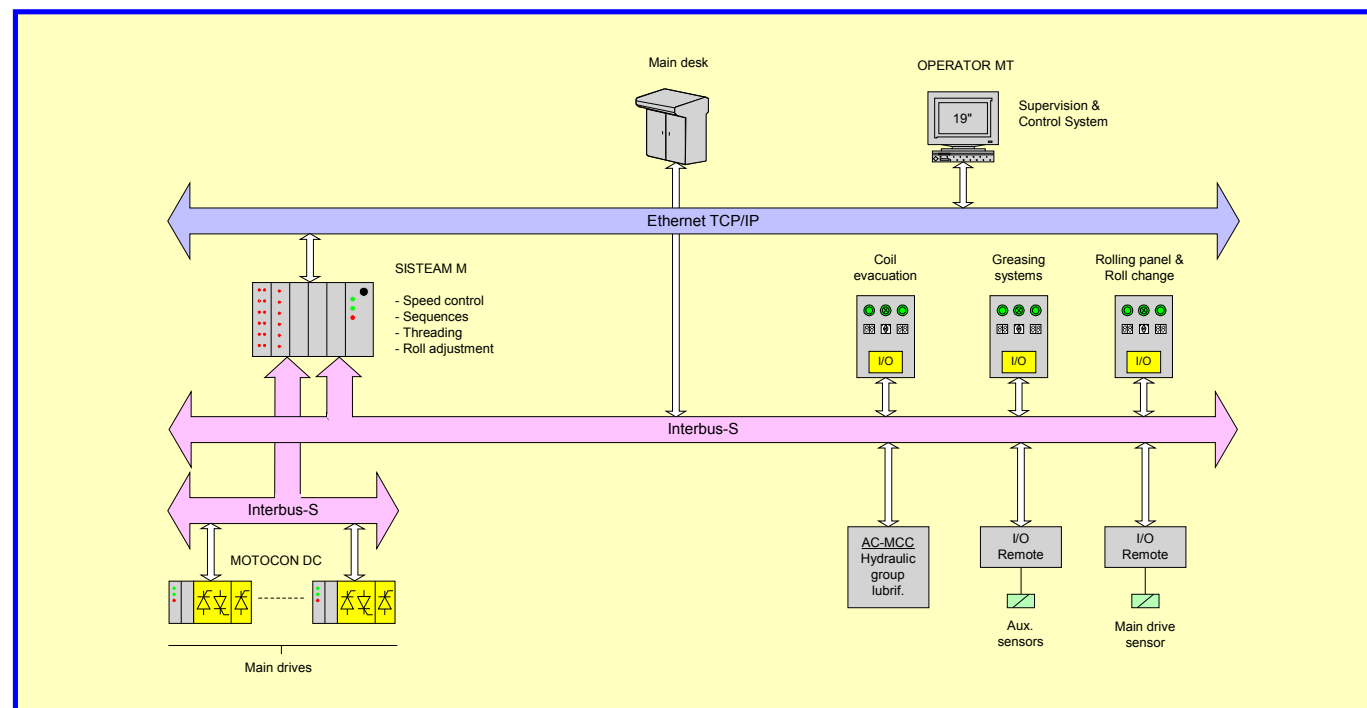

Mill Lay-Out

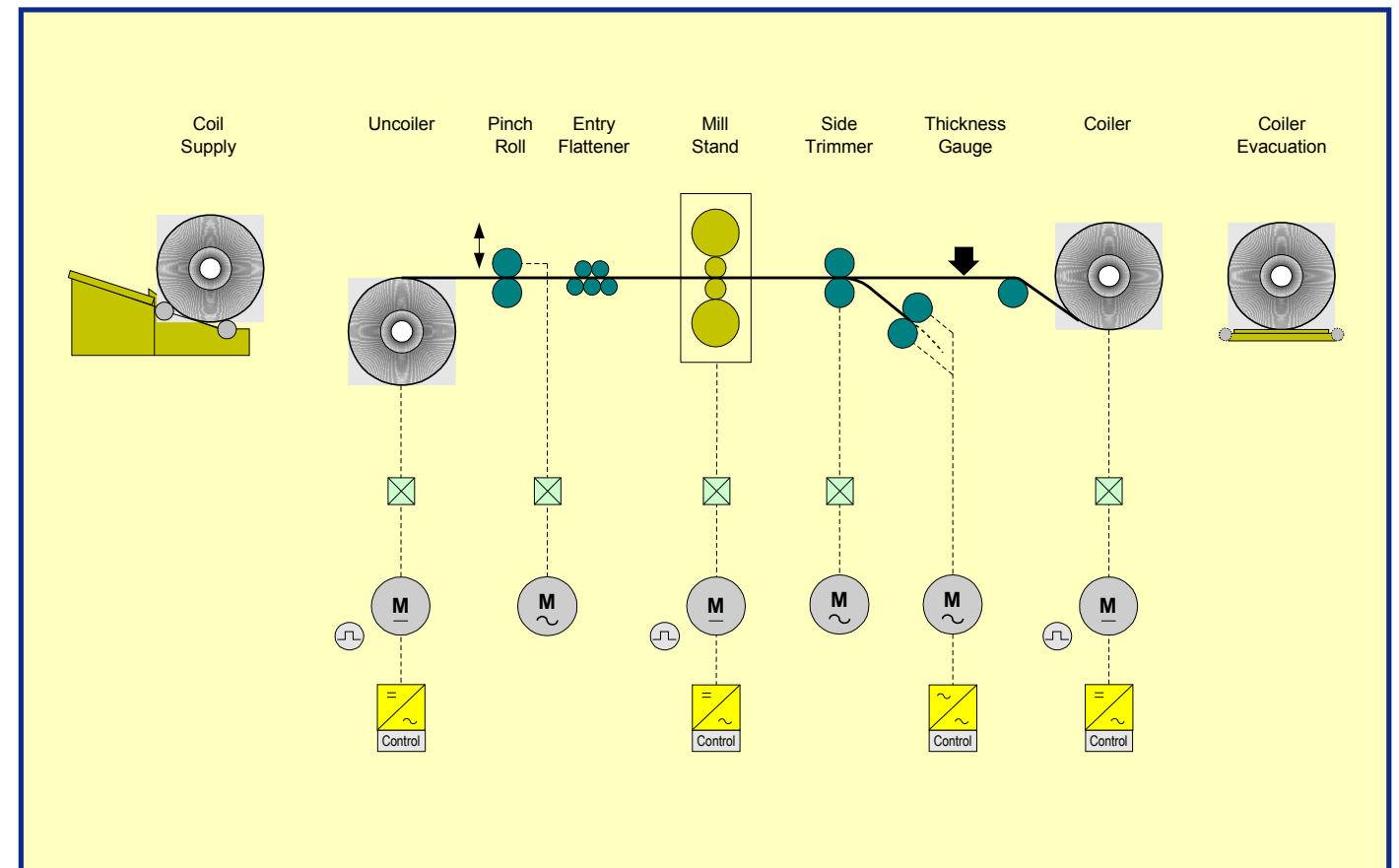

	Uncoiler	Mill Stand	Side Trimmer	Crop Shear	Coiler
Pn (KW)	112	597	2.5	3.75	149
rpm	400 / 1,600	500 / 1,000	1,500	1,500	400 / 1,600
Un (V)	230	700	400	400	230
In (A)	535	930	4.5	6.5	710
i (Reductor)	6.881 or 31.05	2.086 or 8.859	59.54		3.541 or 16.52
Ø (mm)	550 / 1,650	305 / 343	241.3		505 / 1,650

MOTOCON DC

The main drives are driven by DC motors and controlled by four-quadrant thyristor rectifiers (4Q), including field excitation (1Q), using latest generation thyristors.

Its software regulation provides the equipment with an excellent reliability and facilitates its parameterization.

The MOTOCON DC rectifiers feature two formats:

* A compact execution ranging from 30 A. to 1,500 A.

* A cabinet execution from 1,750 A. to 6,800 A. with physically independent control and power units.



Compact MOTOCON DC Rectifiers