



E-lyzer HV Series

ELECTROLYZER RECTIFIER BASED ON IGBT TECHNOLOGY WITH A WIDER DC VOLTAGE RANGE

Great DC current density with a wider voltage range

The INGECON® H2 E-lyzer HV rectifiers feature a great DC current density with up to 6,714 A and a wider DC voltage range up to 1,500 Vdc. Thus, it is the best solution to feed electrolyzers from clean energy sources, especially those electrolyzers with an operation voltage range greater than 1,300 Vdc.

Latest generation electronics

The INGECON® H2 E-lyzer HV rectifiers are based on Ingeteam's latest-generation IGBT technology, that enables AC-to-DC power conversion with no need of any additional harmonic filters nor STATCOM units, thanks to Ingeteam's THD (total harmonic distortion) lower than 3%.

These rectifiers feature a very low power consumption thanks to an efficient power supply electronic board. Furthermore, the hardware of the control unit allows accurate measurements and very reliable protections.

Flexible configuration

These rectifiers feature several power stacks, allowing to connect the DC output to one or several electrolyzers working independently.

Improved medium voltage integration

These rectifiers have been designed in order to facilitate a direct close-coupled connection with the MV/LV transformer. Thus, Ingeteam offers an all-in-one power station that is capable to perform MV to LV conversion while also converting from AC to DC.

Liquid Cooling System (LCS)

The LCS is a closed circuit supplied totally filled and purged, equipped with fast connectors with an anti-dripping system, so it offers zero risk of particle entrance. It has been designed to avoid siphons in order to easily purge it if necessary. The coolant used is a biodegradable glycol water mixture. There is no need of emptying the LCS in order to replace the phases, nor the sensors.

H2 E-lyzer HV Series

Electrolyzer rectifier based on IGBT technology with a wider DC voltage range

Long-lasting design

The rectifiers have been designed to guarantee a long life expectancy, as demonstrated by the stress tests they are subjected to. Standard 2-year warranty, extendable upon request.

Ease of maintenance

All the elements can be removed or replaced directly from the rectifier's front and back sides, thanks to its new design.

Easy to operate

The INGECON® H2 E-lyzer HV rectifiers feature a number of LEDs to show the

rectifier operating status with warning lights to indicate any incidents. All this helps to simplify and facilitate maintenance tasks.

Enhanced protection system

The rectifier is securely connected to the electrolyser using a pre-charge system that smoothly controls the DC current during the electrolyser start-up. Additionally, as an option, the converter can include a flushing system to ensure safe access to the electrolyser for O&M works.

Monitoring and communication

Wi-Fi and dual Ethernet communications supplied as standard. Also included at no extra cost the monitoring applications to record and monitor the rectifier's internal operating variables through the Internet (alarms, real time production, etc.). Two Ethernet communication ports available (one for monitoring and one for plant controlling), allowing fast and simultaneous plant control.

Protections

- DC Reverse polarity.
- Short-circuits and overloads at the output. Insulation failure DC.
- Lightning induced AC surge arresters, type II.
- Motorized DC isolator.
- Motorized AC circuit breaker.
- Hardware protection via firmware.
- Additional protection for the power stack, liquid cooled, IP65 rated and air cooled by a closed loop.
- Integrated stack discharge system.

Optional accessories

- Lightning induced AC surge arresters, type I+II.
- Electrolyser discharge system.

Liquid cooling system

- LCS to refrigerate the IGBTs.
- More optimized component usage: greater thermal stability.
- Less moving components: lower power consumption and less maintenance works.
- No risk of particle entrance.
- C5H anti-corrosive rating with stainless steel components.
- LCS is used in many industries. Thus, it is very reliable, as its components are subject to many validation tests.
- Fast connectors with anti-dripping system Biodegradable glycol water mixture.
- No need of emptying the LCS in order to replace the phases, nor the sensors.

Advantages

- Higher current density.
- Latest generation electronics.
- More efficient electronic protection.
- Enhanced performance.
- Easier maintenance thanks to its new design and enclosure.
- Lightweight spares.
- Components easily replaceable.

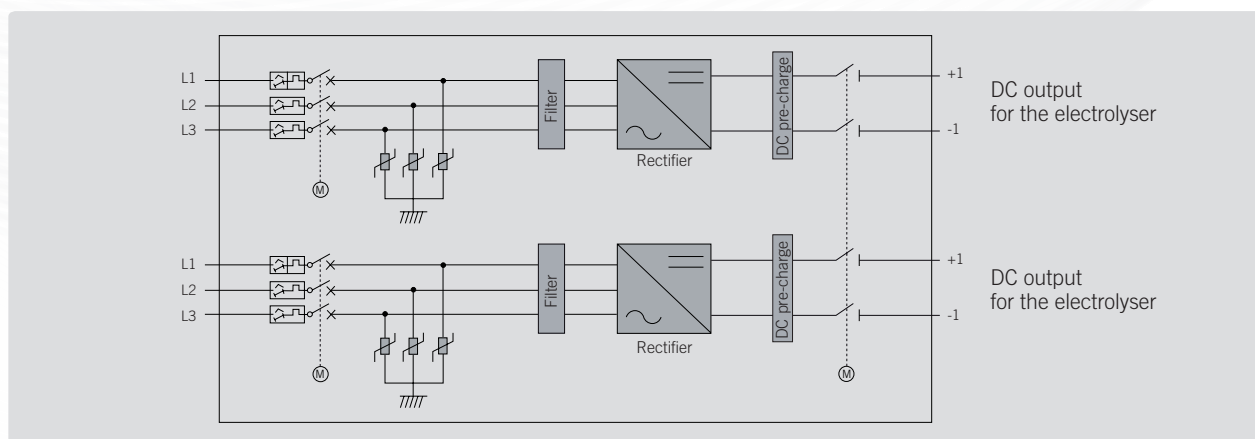

Size and weight (mm)

5,500 kg

INGECON® H2 E6000 HV

OUTPUT (DC)

Voltage Range ⁽¹⁾	350 - 1,500 V
Maximum voltage	1,500 V
Rated current ⁽²⁾	6,000 A
Maximum current	6,497 A
Type of connection	Connection to copper bars
Number of outputs ⁽³⁾	2

OUTPUT PROTECTION

DC Pre-charge	Protection system to control the DC current during the electrolyser start-up
DC switch	Motorized DC load break disconnect
Other protections	Insulation failure monitoring / Electrolyser stack discharge system

INPUT (AC)

Current @1,500 Vdc (30 °C / 50 °C)	5,128 A / 4,142 A
Rated voltage ⁽¹⁾	600 - 840 V IT System
Frequency	50 / 60 Hz
Power Factor adjustable	Yes, 0-1 (leading / lagging)
THD (Total Harmonic Distortion) ⁽⁴⁾	<3%

INPUT PROTECTIONS

Overvoltage protections	Type II surge arresters (type I+II optional)
AC breaker	Motorized AC circuit breaker
Other protections	AC short circuits and overloads

FEATURES

Maximum efficiency	98.9%
Euroefficiency	98.5%
Max. consumption aux. services	15,000 W
Stand-by consumption	370 W

GENERAL INFORMATION

Operating temperature	-20 °C to +60 °C
Relative humidity (non-condensing)	0 - 100%
Protection class	IP65 ⁽⁵⁾
Corrosion protection	External corrosion protection
Maximum altitude	4,500 m (for installations beyond 1,000 m, please contact Ingeteam's hydrogen sales department)
Cooling system	Liquid cooling system and forced air cooling system with temperature control (400V 3 phase + neutral power supply, 50/60 Hz)
Air flow range	0 - 18,000 m ³ /h
Average air flow	12,000 m ³ /h
Acoustic emission (100% / 50% load)	57 dB(A) at 10m / 49.7 dB(A) at 10m
Marking	CE
EMC and security standards	IEC 62920, IEC 61000-6-1, IEC 61000-6-2, IEC 61000-6-4, IEC 61000-3-11, IEC 61000-3-12, EN 50178, FCC Part 15, AS3100
Grid connection standards	IEC 62116, EN 50530, IEC 61683, EU 631/2016 (EN 50549-2, P.O.12.2, CEI 0-16, VDE AR N 4120 ...), G99, South African Grid code, Mexican Grid Code, Chilean Grid Code, Ecuadorian Grid Code, Peruvian Grid code, Thailand PEA requirements, IEC61727, UNE 206007-1, ABNT NBR 16149, ABNT NBR 16150, IEEE 1547, IEEE1547.1, DEWA (Dubai) Grid code, Abu Dhabi Grid Code, Jordan Grid Code, Egyptian Grid Code, Saudi Arabia Grid Code, RETIE Colombia, Australian Grid Code

Notes

(1) For lower voltage values, please contact Ingeteam.

(2) This rated current has been calculated for V_{dcm}=720 V; V_{dc}max=900 V; ambient temperature 35 °C.

(3) These outputs could be connected to the same electrolyser or to two different electrolysers.

(4) For P_{out}>25% of the rated power and voltage in accordance with IEC 61000-3-4.

(5) Except for the LC filter and the air-water heat exchanger, that are IP54.

**Ingeteam Power Technology S.A. - Energy**

Sarriguren (Navarra), ESPAÑA
(+34) 94 828 80 00
energy@ingeteam.com

Ingeteam Power Technology S.A. - Paneles

Sesma (Navarra), ESPAÑA
(+34) 94 869 84 55
paneles@ingeteam.com

Ingeteam Power Technology S.A. - Service

Albacete, ESPAÑA
(+34) 96 724 55 04
service@ingeteam.com

Ingeteam Power Technology S.A. - Technology

Zamudio (Bizkaia), ESPAÑA
(+34) 94 403 96 00
technology@ingeteam.com

Ingeteam Power Technology S.A. - Electronics

Zamudio (Bizkaia), ESPAÑA
(+34) 94 403 96 00
ingeteam.electronics@ingeteam.com

Ingeteam Power Technology S.A. - Converters

Ortuella (Bizkaia), ESPAÑA
(+34) 94 403 96 00
technology@ingeteam.com

Ingeteam Indar Machines S.A.

Beasain (Gipuzkoa), ESPAÑA
(+34) 94 302 82 00
indar@ingeteam.com

Ingeteam R&D Europe, S.L.

Zamudio (Bizkaia), ESPAÑA
(+34) 94 403 96 00

Ingeteam SAS

Labège, FRANCIA
33 (0) 5 61 25 00 00
france@ingeteam.com

Ingeteam UK LTD

East Kibride, REINO UNIDO
+44 (0) 141 488 5290

Ingeteam S.r.l

Castel Bolognese (RA), ITALIA
(+39) 0546 651490
Italia.energy@ingeteam.com

Ingeteam GmbH

Düsseldorf, ALEMANIA
+49 (0) 211 7817 7950
deutschland@ingeteam.com

Ingeteam a.s.

Ostrava-Pustkovec, REPÚBLICA CHECA
+42(0) 59 747 68 20
czech@ingeteam.com

Ingeteam Sp.zo.o.

Warsaw, POLONIA
+48 22 821 99 30
polska@ingeteam.com

Ingeteam Service s.r.l.

Constanta, RUMANIA
(+40) 728 993 202

Ingeteam Bulgaria EAD

Kavarna, BULGARIA

Ingeteam Inc Headquarters

Milwaukee, EE.UU.
(+1) 414 934 4100
usa@ingeteam.com

Ingeteam México S.A. de C.V.

Ciudad de México, MÉXICO
(+52) 55 6586 9930
northamerica@ingeteam.com

Ingeteam México S.A. de C.V.

Juchitán (Oaxaca), MÉXICO
+52 971 281 0996
service@ingeteam.com

Ingeteam SpA

Las Condes, Santiago CHILE
(+56) 232 637 200
chile@ingeteam.com

Ingeteam Uruguay S.A.

Montevideo, URUGUAY
+59 8 2623 2805

Ingeteam Panamá S.A.

Penonomé, PANAMÁ
(507) 66444834
service@ingeteam.com

Ingeteam Ltda.

São Paulo, BRASIL
(+55) 19 30 37 37 73
brazil@ingeteam.com

Ingeteam Ltda.

Curitiba, BRAZIL
(+55) 41 32769841
brazil@ingeteam.com

Ingeteam Power Technology Shanghai Co., Ltd

Shanghai, CHINA
+86 139 1622 4886
liu.yimin@ingeteam.com

Ingeteam Vietnam CO., LTD

Hanoi City, VIETNAM

Ingeteam Power Technology SA

Abu Dhabi, UAE
+971 2 207 666

Ingeteam Power Technology India Pvt. Ltd.

Tamilnadu, INDIA

Ingeteam Morocco SARLAU

Casablanca, MARRUECOS

Ingeteam Australia Pty Ltd

North Wollongong, AUSTRALIA